



# **HIGH-PERFORMANCE WIRELESS RECORDING VIDEO BORESCOPE SYSTEM with ARTICULATING PROBE**

*USER'S MANUAL*



## **DCS1800ART**

*Please read this manual carefully and thoroughly before using this product.*

---

# TABLE OF CONTENTS

Introduction .....	3 – 4
Key Features .....	4
Safety Instructions .....	4
What's in the Case .....	5
Product Overview .....	5 – 6
Setup Instructions .....	7 – 8
Charge Console and Probe Batteries .....	7 – 8
Sync Console and Probe .....	8
Insert SD Card .....	8
Operating Instructions .....	9 – 14
Viewing Live Video on the Console .....	9
Manipulating the Articulating Probe .....	10
Viewing Live Video on a TV Monitor .....	11
Taking Pictures and Recording Videos .....	11
Viewing Photos and Playing Back Videos ..	11 – 12
Accessing SD Card Content .....	12
Navigating the Main Menu .....	13 – 14
Specifications .....	15 – 16
Operating, Maintenance & Troubleshooting Tips .....	16 – 17
Compatible Probes .....	18
Warranty Information .....	19
Return for Repair Policy .....	19

# INTRODUCTION

Thank you for purchasing General Tools & Instruments' (General's) DCS1800ART High-Performance Wireless Recording Video Borescope System with Articulating Probe. Please read this user's manual carefully and thoroughly before using the instrument.

The DCS1800ART has two components: the DCS1800 Handheld Wireless Recording Video Borescope Console and the P18ART-1SM Wireless Transmitting Soft Metal Articulating Probe. The P18ART-1SM is 1m (39 in.) long and has a diameter of 6mm (0.23 in.). The DCS1800ART is also compatible with two other articulating probes from General—the 2m (6.6 ft.) long P18ART-2SM and the 3m (9.8 ft.) long P18ART-3SM.

You can expand the universe of compatible probes to include dozens of wired, non-articulating probes (and a VGA resolution articulating probe) by purchasing General's DCS1800-TR Wireless Probe Handle/Controller. The DCS1800-TR provides both the connector needed to interface with a high-performance wired probe, and the transmitter needed to send the video it captures to the DCS1800 console.

Two tables describing all probes compatible with your DCS1800 system can be found on p. 18.

A thumbwheel on the right side of the articulating probe controller allows you to adjust the brightness of the LEDs illuminating the camera at the end of the probe. Articulation greatly expands the range of inspection possibilities. Being able to change the probe's viewing axis *in situ* by up to 150° in two directions essentially allows you to see around corners, even in close quarters. Separately, the ability to detach the monitor from the probe also increases application flexibility by, for example, enabling two-handed operation, as shown in the photo at right.



The DCS1800 console has three operating modes: Preview, Playback and Menu:

- **In Preview mode**, video framed by the camera's field of view is displayed in real time on the console's LCD. The console automatically enters this mode when powered on. A front-panel button allows you to enlarge (zoom in on) a target by 50% (a zoom level of 1.5X). The same button allows you to "mirror" video, making it possible to read serial numbers seen and "reversed" by an attached probe with a mirrored viewing tip. In Preview mode, real-time video also can be exported through an included video cable to any NTSC- or PAL-format TV monitor with RCA input jacks. Operating in Preview mode, the DCS1800 console also allows you to record inspection videos (at 320 x 240 pixel resolution) and photos (at 640 x 480 pixel resolution) on an included SD memory card by pressing icon-labeled buttons on the console's front panel. The remaining front-panel buttons enable access to Playback and Menu modes.
- **In Playback mode**, you can browse the SD card for saved video and picture files and view the media on the console's LCD or a larger TV monitor. Video clips and photos also can be viewed on a PC by removing the SD card and plugging it into the computer directly or through a card reader. Because videos are saved as .asf files

and photos as .jpg files, applications found on most PCs (Microsoft Windows Media Player and Microsoft Office Picture Manager) can open the files. The 2GB SD memory card included in the DCS1800ART case can store at least 5 hours of video, recorded at an average of 6 Mbytes/minute, in addition to hundreds of photos.

- **In Menu mode**, you use familiar scrolling motions and responses to dialog boxes to navigate a main menu with six submenus. When selected, submenu items execute “housekeeping” functions such as deleting files, setting the date and time, enabling or disabling date and time stamps, choosing any of 14 languages for display indications, selecting a Video out format and adjusting the console’s Auto Power Off trigger. One of the submenus has a sub-submenu that allows you to adjust four attributes (brightness, contrast, hue and saturation) of video viewed on the console or an external monitor.

---

## KEY FEATURES

- Slim (6mm diameter), wireless, waterproof IP67 probe with articulation range of  $\pm 150^\circ$  and high-quality camera at its tip. Camera lighting provided by four adjustable-brightness white LEDs.
- Operating flexibility is maximized when console is detached from probe. In this mode, video captured by probe can be sent to console from up to 150 ft. (46m) away on any of four wireless channels.
- Console has 3.5 in. diagonal color LCD for viewing probe video instantly and saved video clips and pictures later
- Compatible with dozens of high-performance camera-tipped probes from General (see p. 18)
- 14 available menu languages
- Familiar menu-driven user interface for viewing and recording videos and photos on standard SD memory card (2GB card included) and playing back media on console, TV or PC
- Rechargeable Lithium-ion batteries with 4-hour capacity
- 1-year limited warranty

---

## SAFETY INSTRUCTIONS

### **CAUTION!**

***Never insert any probe attached to the DCS1800 console into any structure or space known or suspected to contain live electric wiring***

- The DCS1800 system is intended for industrial applications only. Do not use a compatible probe for human or any other biological inspections.
- Never insert an attached probe into any flammable gas or liquid (including fuels in an oil, gasoline or diesel tank)
- Do not disassemble the console. Doing so creates a potentially fatal electrical hazard (and voids the warranty as well).

# WHAT'S IN THE CASE

The DCS1800ART system comes in a custom hard plastic protective carrying case. Inside the case are:





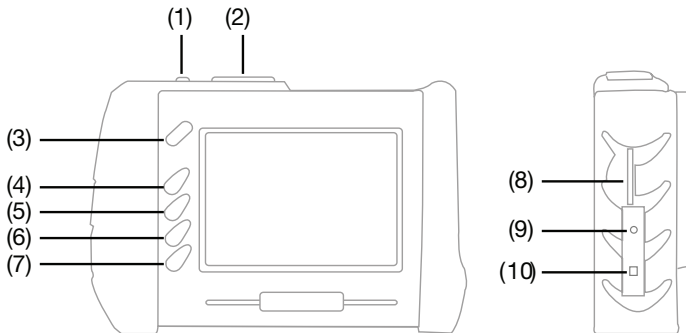

- The DCS1800 console. The console integrates an LCD monitor, circuitry for wirelessly connecting to a high-performance camera-tipped probe from General, and front-panel controls for controlling the camera's lights, adjusting system parameters, and recording and playing back videos and photos captured by an attached probe.
- The P18ART-1SM Wireless Articulating Probe, with a length of 1m (39 in.) and a diameter of 6mm (0.23 in.)
- A 2GB SD memory card
- An AC adapter/battery charger for a 110/220VAC supply. The adapter has a 5.5VDC, center-positive output plug.
- A video cable for connecting the DCS1800 console to a TV monitor. The cable has RCA plugs at one end and a mini-stereo plug at the other end.
- A small flat-blade screwdriver for changing the wireless channel of the console and probe
- A soft cloth, a bottle of liquid, and cotton swabs for cleaning the console
- A package of desiccant
- This user's manual

# PRODUCT OVERVIEW



Fig. 1 shows the names and locations of all of the controls, ports and jacks of the DCS1800 console. Table 1 details how the function of each front-panel button changes with the console's operating mode. Fig. 2 shows the names and locations of the controls and main physical features of the P18ART-1SM wireless articulating probe. Familiarize yourself with the labels, positions and functions of all buttons and connectors before moving on to the Setup Instructions and Operating Instructions.

**Fig. 1. The controls, ports and jacks of the DCS1800 console**



- |   |  |                                   |    |   |   |
|---|--|-----------------------------------|----|---|---|
| 1 |  | Start/Stop Video Recording Button | 6  |  | OK/Menu Enter/Save/Enter Menu mode Button |
| 2 |  | Snapshot Button                   | 7  |  | Esc Escape/Zoom/Mirror Button             |
| 3 |  | Power On/Off Button               | 8  |   | SD Card Socket                            |
| 4 |  | Previous Video/Photo Button       | 9  |   | TV Out Jack                               |
| 5 |  | Next Video/Photo Button           | 10 |   | AC Adapter Jack                           |

**Table 1. The DCS1800 console's multi-function buttons**

Button Label	In Preview Mode	In Playback Mode	In Menu Mode
▲	Switches to Playback mode	Selects next-oldest video or photo	Moves up one line
▼	Switches to Playback mode	Selects next-newest video or photo	Moves down one line
<b>OK/Menu</b>	Switches to Menu mode	Offers option to delete selected video or photo	Executes highlighted command
<b>Esc</b>	<b>Pressed briefly</b> , enlarges target by 50% (zooms 1.5X) <b>Pressed and held</b> , mirrors video	Switches to Preview mode	Switches to Preview mode
	Takes a picture (stores .jpg photo on SD card)	Recalls next photo or pauses/plays video clip	Displays repair data or opens submenu of video attribute options
	Starts/stops recording an .asf video on SD card	Switches to Preview mode	Switches to Preview mode

**Fig. 2. The controls and physical features of the P18ART-1SM Wireless Articulating Probe**

- (1) Soft metal probe
- (2) Camera head
- (3) Flexible neck
- (4) Probe controller
- (5) Articulation control wheel
- (6) On/off switch & brightness thumbwheel
- (7) Channel selector switch
- (8) Probe charge indicator LED
- (9) Mini-USB jack

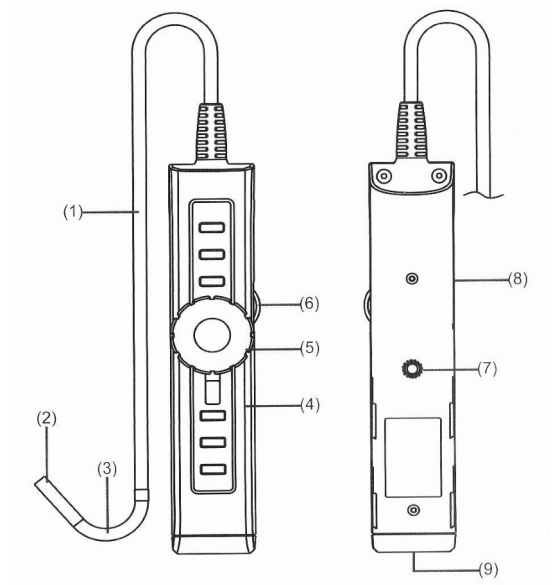

# SETUP INSTRUCTIONS

## CHARGE CONSOLE AND PROBE BATTERIES

To prepare to power the system on for the first time, securely attach the DCS1800 articulating probe controller to the back of the DCS1800 console using the two motions shown at right. Plug one end of the supplied AC adapter/battery charger into a wall socket. Then swing the black rubber protective flap away from the right side of the DCS1800 console to expose the AC adapter jack (Fig. 1, Callout 10). Insert the cylindrical plug at the end of the adapter/charger cable into the AC adapter jack. This will begin charging the console's battery and the probe's battery at the same time. Next, power on the probe by rotating the probe controller's thumbwheel (Fig. 2, Callout 6) downward until you feel and hear a click.

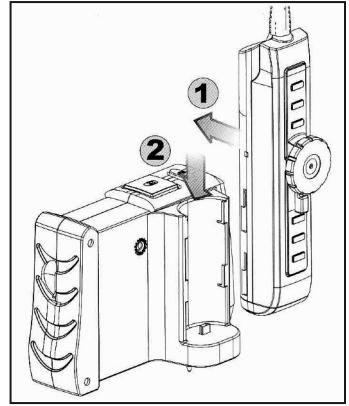

**Table 2. Correlating the color of the LED on the probe controller with battery charge**

LED COLOR	BATTERY STATUS	COMMENT
Green	In use	Working under full battery
Dark Red	Low battery	Recharge battery when dark red light appears during usage
Orange	Charging while in use	Charging while in use
Red	Charging with power off	Charging with power off
None	Full battery with power off	Light dims when battery is fully charged

Next, press the red the  button on the console (Fig. 1, Callout 3) and hold it for at least five seconds. The LCD will illuminate and briefly show the word "CAMERA" on the left and an icon indicating the charge of the console's battery on the right (both in green), superimposed on video being captured in real time by the camera at the end of the probe.

Practice using the thumbwheel on the probe controller to adjust the intensity of the camera's lighting. In a brightly lit room, moving the thumbwheel has a big effect on the brightness of the LEDs at the tip of the probe, but a much smaller effect on the brightness of video on the screen. The on-screen impact of changing brightness is more pronounced in dark environments.

To power off the DCS1800 console, push the  button and hold it for at least five seconds.

It will take several hours to fully charge the console and probe batteries the first time. **You cannot replace either battery**, which can only be replaced by General-authorized service personnel. **Do not open the case of either component in an attempt to**

**change the battery yourself.** Doing so creates a potentially fatal electrical hazard (and voids the warranty as well) with the AC adapter plugged in.

With proper care (charging the batteries often, and never allowing them to completely discharge), you can expect each battery to last four or five years. Fully charged batteries should power at least four hours of operation.

## ***SYNC CONSOLE AND PROBE***

It's important to realize that the DCS1800 console is now showing video only because the probe is physically attached to it. For most inspection applications, you will want to detach the probe from the console and use its built-in transmitter to send video to the console's LCD wirelessly. Detaching the two components frees up both of your hands. You can then use one hand to feed the probe into the area you want to inspect, and the other hand to adjust the probe's articulation angle.

The probe and console can communicate wirelessly only if both components are operating on the same channel. Four channels centered on 2.4GHz are available. Both components may have already been set to the same channel at the factory. To discover whether that is the case, detach the probe from the console. If the console's LCD resumes showing probe video after a brief delay, the two units are already operating on the same channel and there is no need to sync them.

If detaching the probe from the console causes the video to disappear, leaving static on the screen, you must sync the two components.

**To synchronize the transmitting frequency of the probe with the receiving channel of the console,** you can either change the channel of the probe or the channel of the console. In either case, you will use the small flat-blade screwdriver included in the case. The channel selector switch of the console is on the rear of the unit, in the center near the top. The channel selector switch of the probe controller is also on the back of the unit (Fig. 2, Callout 7).

Since there are only four available channels, the fastest way to sync the two components is to use the screwdriver to move the channel selector switch of either component through all four of its possible positions. When probe video appears on the console, you have succeeded in syncing the two units.

## ***INSERT SD CARD***

This final setup step enables storage of video clips and photos. Remove the supplied 2GB SD memory card from its packaging. Discard the packaging, but save the plastic storage case.

Push the SD card into the socket on the right side of the console (Fig. 1, Callout 8). Be sure the card's gold contacts are facing front and enter the socket first. Push in the card until you feel it spring back and you hear a click.

Note that when you inserted the SD card, a new icon with four bars appeared briefly on the bottom right of the console's LCD. This icon indicates the used capacity of the memory card. Four green bars indicate a full SD card. No green bars indicate an empty card.

To remove the card later, push it in gently until you hear a click and the card pops out far enough for your fingers to grab.



# OPERATING INSTRUCTIONS

## VIEWING LIVE VIDEO ON THE CONSOLE

Continue charging the console and probe batteries until both are fully charged. To determine whether the console's battery is fully charged, either power the console off and then on again or briefly press the **Esc** button to temporarily activate the zoom function (as explained and shown below). The battery status will briefly appear on-screen, as explained and shown below as well..

The charge of the probe's battery is indicated by the color of the LED on the side of the controller (Fig. 2, Callout 8). Table 2 on p. 7 correlates the LED's color with the probe's charge level.

While the batteries continue to charge, General recommends that you become familiar with the DCS1800 console's controls, indicators and menu options before taking the unit out into the field. The system operates the same way whether powered by batteries or the AC adapter.

To begin, power off the unit by pressing and holding the  button on the console. Then press and hold the button again to power the console back on. Each time the console is powered on, the screen shown below will appear briefly, superimposed on live video captured by the camera probe. Together, the number of bars in each icon represent the DCS1800 console's two "vital signs"—battery charge and available memory capacity.

The number of filled-in bars at the bottom of the screen reflects the amount of data currently stored on the SD card. A full card would be indicated by four bars. The more filled-in bars in the  icon, the higher the current level of battery charge. Four bars indicate a fully charged battery.

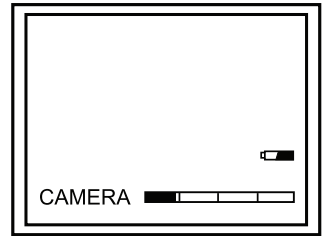

Finally, note the dual function of the **Esc** button in Preview (live video) mode:

- **Press the Esc button briefly** and targets will be enlarged by 50% as the camera's field of view is reduced by that amount. A red plus sign (+) will appear on-screen and remain there after the available memory capacity bars and the battery charge icon make a brief appearance.
- **Press and hold the Esc button** and video will be mirrored horizontally, as shown in the two photos at right. The effect makes it possible to read text or serial numbers "reversed" by an attached probe with a mirrored viewing tip—by undoing the reversal. A red "M" will appear on-screen to indicate that video is being mirrored.

You can mirror and zoom videos at the same time by pressing the **Esc** button briefly, and then pressing and holding the button. In this case, a red M and a red plus sign will appear on-screen together.

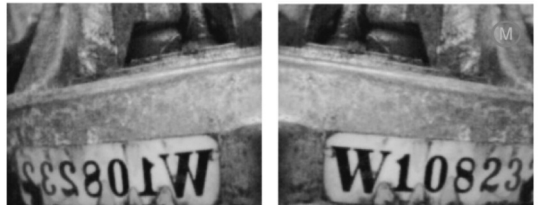

## MANIPULATING THE ARTICULATING PROBE

Next, get used to manipulating the articulating probe. Typically, borescope users insert their probe into an orifice (a hole in a wall or an engine's cylinder, for example) or into an inaccessible or hazardous area (the back or an equipment rack or an engine compartment, for example) to view components or environments that would otherwise be invisible. Compared to an obedient probe, your soft metal articulating probe is more flexible, but it does not retain its shape. Its obvious advantage is articulation. Using the articulation control wheel (Fig. 2, Callout 5), you can turn the probe tip to inspect targets off the main axis of the probe while it is in a tight space, without having to remove and re-insert the probe.

The articulation control wheel allows you to bend the tip of the probe up to  $150^\circ$  to the left or right. To bend the tip to the left, rotate the wheel counterclockwise (see photos below left). To bend the tip to the right, rotate the wheel clockwise (see photos below right).

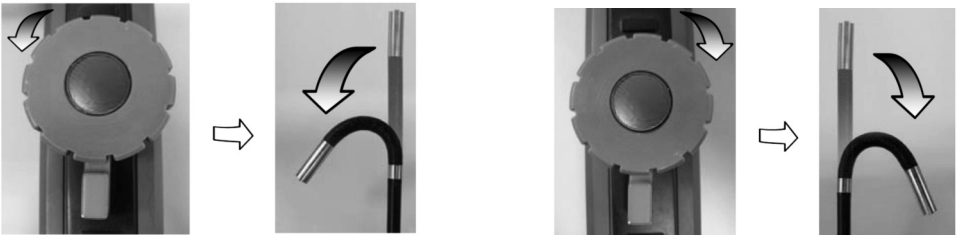

To lock the tip of the probe into its bent position, move the red lever below the control wheel to the left (see photo at right). Remember to unlock the probe tip (by moving the red lever to the right) before using the control wheel to move it again.



Be aware that your application environment may limit how much you can articulate the probe. For example, if you are inspecting a 1 in. diameter pipe, you will be unable to bend the probe tip more than a few degrees; any more would bring the tip into contact with the pipe's inside wall. The relevant P18ART-1SM specification is that 2 in. (50mm) of clearance is required for  $90^\circ$  articulation (in either direction).

In many cases—inspecting the interior of an engine cylinder, for example (see photo at right)—adequate clearance will not be an issue. In fact, the  $\pm 150^\circ$  articulation range enables “look back” inspections of intake and exhaust valves from within the cylinder.

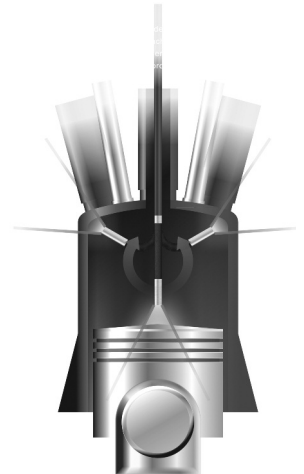

## VIEWING LIVE VIDEO ON A TV MONITOR



Your DCS1800 system comes with a video cable for connecting the console to a TV or TV monitor that uses either the NTSC or PAL analog broadcast standard. By making the connection, you can view live video (or saved videos and pictures) on a screen larger than the console's.





To implement the connection in hardware, insert the stereo mini-plug of the provided cable into the TV Out jack of the console (Fig. 1, Callout 9). Then insert the yellow RCA plug at the other end of the cable into the Video In jack of your TV or TV monitor, leaving the white RCA plug unconnected. Be sure to set the TV input to external video.



Real-time videos shown on an external monitor can be enlarged by pressing the **Esc** button. But videos cannot be mirrored, as they can when viewed on the console's LCD.

To activate the connection in software and begin exporting console's video to a TV, refer to the instructions for the **VIDEO FORMAT** and **AV OUTPUT** lines in the "Navigating the Main Menu" section of this manual, beginning on p. 13.

## TAKING PICTURES AND RECORDING VIDEOS







**To take a picture**, make sure the console is in Preview mode (with live video appearing on the LCD) and press the  button. Doing so creates a .jpg file of the frame being displayed at that moment and stores it on the SD card. A red  icon briefly appears at the lower left of the LCD to confirm that a picture was taken. The console automatically returns to Preview mode after taking a picture.

**To record a video**, make sure the console is in Preview mode and press the  button. Doing so begins creating an .asf video file (with MPEG-4 compression) for storage on the SD card. A red  icon appears at the lower left of the screen to confirm that a recording is in progress, and it remains there for the duration of the video. To stop recording, press the  button again. This makes the red  icon disappear and returns the console to Preview mode.







While a video is being recorded, all console buttons other than the  and  buttons are disabled. Pressing the  button takes a picture, stops recording video and returns the console to Preview mode.



The console will be unable to store videos and pictures if its SD memory card is full, write-protected or damaged. When the instrument senses any of these conditions, it will superimpose the word **FULL** on the screen in Preview mode. To remedy the situation, either replace the full SD card by another card with spare capacity, or delete files individually or in bulk. Instructions for deleting files can be found later in this user's manual.

## VIEWING PHOTOS AND PLAYING BACK VIDEOS

**To view a picture** or play back a video (or more than one picture or video) on the console's LCD or a TV monitor, switch the unit out of Preview mode and into Playback mode by pressing the  or  button (Fig. 1, Callouts 4 and 5, respectively). In Playback mode, pressing the  button repeatedly recalls all photos and videos from memory in the reverse order in which they were created and stored (in other words, the newest first and the oldest last). Each press of the  button selects the next oldest picture or video. Videos begin playing automatically. A green  icon and a red  icon are superimposed

on the video at the lower left of the screen. After a photo has been on-screen for 60 seconds, the console automatically switches to Preview mode.

Pressing the  button while a video is playing pauses playback and replaces the red  icon with a red  icon. Pressing the  button again resumes play and restores the red  icon. Pressing the  button while a video is playing switches to Preview mode. Pressing the  button while a picture is being displayed selects the next newest file.

While each photo and video is on-screen, pressing the **OK/Menu** button gives you the option to delete its file. Pressing the button calls up a dialog box with the word **DELETE** above the flashing word **NO**. Pressing the  or  button changes the flashing word to **YES**. When the correct answer (for you) appears, press the **OK/Menu** button to choose that action.

## ACCESSING SD CARD CONTENT

Photos and videos stored on the SD card also can be viewed on a PC. If your computer has an SD card slot, you can eject the memory card from the console and plug it directly into a PC. If your PC does not have an SD card slot, you can purchase a USB SD card reader (Part No. SDRD1) from General.

If you choose to remove the SD card from the console and plug it into a PC, either directly or through a card reader, remember to eject the card from the PC once you are done viewing (and/or copying) the files it contains. Depending on your PC's startup settings, your computer may fail to restart following its next shutdown if the SD card remains inserted. The PC's operating system may try to reboot from the SD card and be unable to do so.

Details of the SD card's file structure are worth mentioning because assigned file names contain useful information. The figure below illustrates the hierarchy. It shows that the SD card contains one folder named "DCIM" and one subfolder named "100MEDIA". The 100MEDIA folder contains all stored photo and video files, identified by their .JPG and .ASF extensions. **You should not rename the DCIM and 100MEDIA folders while the SD card is inside your PC. If you rename either folder, the console will fail to recognize the SD card the next time you plug it in.**

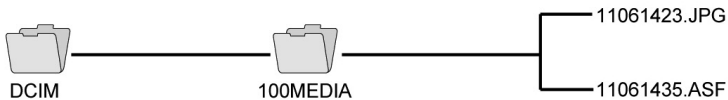

The 8-digit file names identify the date and time when the file was created. The first two digits represent the month and day, and the last six digits represent the hour, minute and second. For example, the upper file name shown above identifies a photo file that was created on January 1 at 06:14:23 a.m. The lower file name identifies a video file that was created on the same day at 06:14:35 a.m.

The console's file-naming convention uses the letters A through C to represent the months October through December, and the letters A through V to represent days of the month from 10 through 31. For example, a file created on October 11 would begin with the letters AB (A for 10 and B for 11). As another example, a file created on November 30 would begin with the letters BU (B for 11 and U for 30).

Finally, the file-naming convention uses military (24-hour) time. For example, a name with the last six digits 142531 would indicate a file created at 02:25:31 p.m.

## NAVIGATING THE MAIN MENU

The main menu of the DCS1800 console provides access to the following housekeeping and operational functions:

- Bulk file erasure
- Video exporting
- Setting the date and time
- Choosing a display language
- Selecting a TV format and adjusting video attributes
- Enabling/disabling and adjusting the Auto Power Off function

Menu mode has a hierarchical structure and uses prompts and dialog boxes familiar to anyone who has used an Automated Teller Machine (ATM). The only constraint on using the menu is your own response speed. **If no selection is made within 10 seconds following entry into Menu mode, the console will automatically revert to Preview mode.** The same time constraint applies to selections within submenus. **If you do not respond to a prompt (indicated by a flashing word or line of text) within 10 seconds, the console will switch back to Preview mode**—its default operating state.

To access the main menu, press the **OK/Menu** button to enter Menu mode. Doing so brings up the screen shown at right.

To navigate the main menu, use the **▲** and **▼** buttons to move up and down until the parameter you wish to change is highlighted and flashing in green. Then push the **OK/Menu** button to select it and call up its submenu.

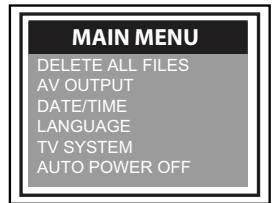





The **DELETE ALL FILES** line gives you two options (yes and no) that can be selected using the **▲** and **▼** buttons. The sequence is similar to the previously described procedure for deleting an individual photo or video.



The **AV OUTPUT** line allows you to send the real-time video stream shown on the display unit out through the unit's TV out jack to an NTSC or PAL TV monitor. The console's display will turn black until you select this option again. Before activating this function, make the physical connection described in the "Viewing Live Video on a TV Monitor" section.

The **DATE/TIME SETUP** line allows you to set the console's calendar and clock. Doing so is necessary only if you wish to keep track of your photo and video files by date and time.



When **DATE/TIME SETUP** is selected, the screen that appears has the year flashing in green. To increase the value, press the **📅** button. To decrease the value, press the **📺** button. Once you have set the year, advance to the next field—the month—by pressing the **▼** button. Set the month as you did the year, by using the **▲** and **▼** buttons to increase or decrease the value by one unit per button press. Repeat this process until all six date and time components have been set. To back up from any field to the previous field, press the **▲** button.

The bottom line of the **DATE/TIME SETUP** screen also allows you to choose whether or not to superimpose the date and time on the display in Preview mode. The default condition is “display off”, meaning the date and time are not displayed. To always superimpose the date and time, navigate down to the bottom line until the word **OFF** below the word **DISPLAY** is flashing in green. Then push either the  or  button to change the flashing word to **ON**. Finally, press the **OK/Menu** button to save the setting.

The **LANGUAGE** line of the main menu allows you to view the main menu, as well as the **DELETE** screens for individual photos and videos, in any of 14 languages (English, Spanish, Italian, French, German, Portuguese, Traditional Chinese, Simplified Chinese, Japanese, Danish, Dutch, Polish, Russian and Bulgarian). Use the  and  buttons to navigate to the language you wish to use and then push the **OK/Menu** button.

The **VIDEO FORMAT** line enables you to choose either **NTSC** or **PAL** formatting of the videos you export to a TV monitor. Press either the  and  button to make your choice and then push the **OK/Menu** button to save the setting.

Pressing the  button with either **NTSC** or **PAL** flashing on the **VIDEO FORMAT** submenu opens a sub-submenu with the following lines: Brightness, Contrast, Hue and Saturation. You can use this submenu to change any of those four video attributes from the default factory settings.

The default factory settings are: 00 for Brightness, 40 for Contrast, 00 for Hue, and 50 for Saturation. To change the value of any attribute, navigate to its line and press the **OK/Menu** button when its name begins flashing in green. The screen will then go dark except for the name of the attribute at the top. To increment the value from the factory default value, press the  button (the opposite of what you'd expect). To decrement the value, press the  button (again, the opposite of what you'd expect).

There are 256 options for the value of each video attribute, and the attributes are identified and ordered by hexadecimal (base 16) numbers. For example, pressing the  button to increment the value 09 produces 0A (the number 10 in base 16 notation); further increments yield 0B through 0F (the numbers 11 through 15). Incrementing 0F produces the value 10 (the number 16 in hexadecimal notation). Similarly, incrementing 19 produces the value 1A; further increments yield 1B through 1F. Incrementing 9F produces A0, further increments produce A1 through A9, and further increments produce AA through AF. Incrementing AF produces BA, and so on, through FF (the number 255 in hexadecimal notation). Incrementing FF completes the cycle, producing a value of 00.

The **AUTO POWER OFF** line of the main menu is not visible on the screen that first appears after you press the **OK/Menu** button to put the console into Menu mode. To show the line, scroll down past the **VIDEO FORMAT** line. When the **AUTO POWER OFF** line appears, flashing in green, press the **OK/Menu** button.

By default, the **AUTO POWER OFF** function of the console is disabled. To enable it, and to choose how quickly to power off the instrument following a period of inactivity, navigate to one of the four options (5, 10, 15 or 30 minutes) and press the **OK/Menu** button. To re-disable the function later, enter Menu mode, scroll down to the **AUTO POWER OFF** line, press the **OK/Menu** button, select **DISABLE** and press the **OK/Menu** button again to save the setting.

---

# SPECIFICATIONS

## *DCS1800 CONSOLE*

---

Display Type	Color TFT LCD
Display Size	3.5 in (89mm) diagonal
Display Resolution	320 by 240 pixels (QVGA)
Video Recording Resolution	320 x 240 pixels (QVGA)
Video File Format	.asf
Photo Recording Resolution	640 x 480 pixels (VGA)
Photo File Format	.jpg
Video Out Formats	NTSC, PAL
Video Frame Rate	30 frames per second (fps)
Receiving Frequencies	2.414GHz, 2.432GHz, 2.450GHz, 2.468GHz
Compression Format	Compatible with MPEG4
Signal-to-Noise Ratio	42dB or greater
Recording Medium	Standard-size SD card
Interfaces	AV Out, USB 2.0
Languages	English, Spanish, Italian, French, German, Portuguese, Traditional Chinese, Simplified Chinese, Japanese, Danish, Dutch, Polish, Russian, Bulgarian
Power Source	Rechargeable 3.7V Li-ion battery
Power Consumption	1.8A @ 5.5VDC
Operating Temperature	-4° to 140°F (-20° to 60°C)
Storage Temperature	-4° to 140°F (-20° to 60°C)
Recharge Temperature	32° to 104°F (0° to 40°C)
Console Dimensions	8.5 x 4.7x 1.4 in. (215 x 120 x 36mm)
Console Weight	13.4 oz (380g)

---

## ***P18ART-1SM PROBE***

Length	1m (3.28 ft)
Diameter	6mm (0.23 in.)
Depth of Field	0.4 to 12 in. (10 to 300mm)
Field of View	46° (horizontal), 34° (vertical), 56° (diagonal)
Resistances	To water, oil & dust per IP67 standard
Camera Lighting	2 white LEDs
Articulation Angle	±150°
Clearance Required for 90° Articulation	2 in. (50mm)
Transmitting Frequencies	2.414GHz, 2.432GHz, 2.450GHz, 2.468GHz
Operating Temperature	32° to 131°F (0° to 55°C)

## **OPERATING, MAINTENANCE & TROUBLESHOOTING TIPS**

- Never remove the SD card while taking a picture or recording a video. Doing so may damage the card and erase or corrupt the photo or video.
- If the LCD remains or goes dark, the first two things to confirm are that the console and probe batteries are adequately charged, and that both components are operating on the same channel.
- If live video begins to look spotty, streaky or intermittent, the likely reason is an under-charged battery. Plug in the AC adapter/battery charger immediately.
- Video recording requires an SD card with a fast writing speed. For maximum video quality, General recommends SD cards with a writing speed of 80X or higher.
- Avoid using corrosive liquids such as alcohol to clean either the LCD or the camera head. To clean the camera lens and LEDs, use a cotton swab and a small amount of cleaning solution. To clean the LCD, use the provided cloth, cotton swabs and liquid. To clean the plastic housings of the console and probe controller, use a soft, dry cloth.
- Operate and store the console and probe only in a cool (under 140°F or 60°C), dry, well-ventilated place. Avoid exposing either unit to sunlight for long periods of time.
- To avoid damaging the console, use only compatible probes and accessories.



- The P18ART-1SM probe is flexible to make it easy for you to inspect hard-to-reach areas. Never insert or bend it by force, and never over-bend any part of the probe. Specifically:

- Do not bend the last 1 to 2 inches (25 to 50mm) of the probe by more than  $70^{\circ}$
- Do not bend the probe at any other point by more than  $90^{\circ}$

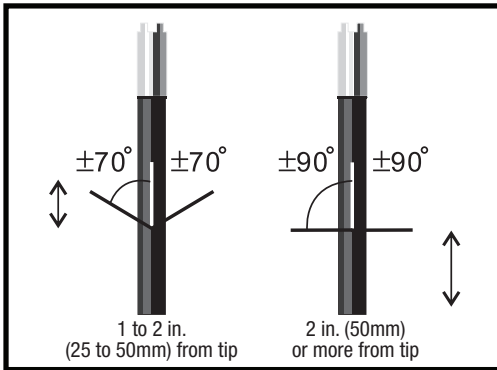

- To avoid permanently damaging the delicate wires and fiber optic cables inside the probe, never curl it into a circle with a diameter of less than 6 in. (150mm).
- Never use the probe or camera head to modify surroundings or to clear pathways or clogged areas.
- The camera head, LEDs and thread protector ring are waterproof, but not acid-proof or fire-proof. Do not touch acidic, corrosive or hot materials or they will ruin the head.
- When inspecting a vehicle, shut off the engine. Metal and liquid under the hood may be hot. Do not get oil or gas on the camera head.
- If condensation forms inside the camera lens, let it evaporate before using the probe again.
- Do not try to disassemble any part of the console, probe or probe controller. Doing so creates an electrical hazard with the AC adapter plugged in, could damage the probe, and voids the limited warranty.

# COMPATIBLE PROBES

The tables below describe and compare all probes compatible with the DCS1800 system console.

## COMPATIBLE PROBES

Model No. (SKU)	Probe Description	UPC	Camera Head Diameter	Probe Length	Depth of Field
P18ART-1SM	Wireless Transmitting Soft Metal Articulating Probe	01419 6	6mm (0.23 in.)	1m (3.3 ft.)	0.4 to 12 in. (10 to 300mm)
P18ART-2SM		01477 6		2m (6.6 ft.)	
P18ART-3SM		01489 9		3m (9.8 ft.)	

## PROBES MADE COMPATIBLE BY DCS1800-TR WIRELESS PROBE HANDLE/CONTROLLER

Model No. (SKU)	Probe Description	UPC	Camera Head Diameter	Probe Length	Depth of Field
P16ART-1SM	Soft Metal Articulating Probe	01418 9	6mm (0.23 in.)	1m (3.28 ft.)	0.4 to 12 in. (10 to 300mm)
P16ART-2SM		01476 9		2m (6.6 ft.)	
P16ART-3SM		01500 1		3m (9.8 ft.)	
P16HPART	VGA Resolution Articulating Probe	01579 9		1m (3.28 ft.)	
P16181SR-M	Flexible-Obedient Probe	01408 0	5.5mm (0.22 in.)	1m (3.28 ft.)	
P16182SR-M		01409 7		2m (6.6 ft.)	
P16183SR-M		01410 3		3m (9.8 ft.)	
P16181SM-M	Soft Metal Probe	01411 0	5.5mm (0.22 in.)	1m (3.28 ft.)	
P16183SM-M		01412 7		3m (9.8 ft.)	
P16185SM-M		01414 4		5m (16 ft.)	
P161810SM-M		01414 1		10m (32 ft.)	
P161830SM-M		01415 8		30m (98 ft.)	
P161839-M		Ultra-Slim Flexible-Obedient Probe		01424 0	3.9mm (0.15 in)
P16182-39	01556 8		2m (6.6 ft.)		
P16183-39	01557 5		3m (9.8 ft.)		
P1618FS-49	Switchable Front/Side View Flexible-Obedient Probe	01481 3	4.9mm (0.19 in)	1m (3.28 ft.)	
P16182-49		01554 4		2m (6.6 ft.)	
P16183-49		01553 7		3m (9.8 ft.)	
P16181HP	VGA Resolution Probe	01576 6		1m (3.28 ft.)	0.4 to 12 in. (10 to 300mm)
P1618SV-1SM	Side View Soft Metal Probe	01407 3	5.5mm (0.22 in.)	1m (3.28 ft.)	0.25 to 6 in. (6.4 to 150mm)
P1618SV-1SR	Side View Flexible-Obedient Probe	01406 6		1m (3.28 ft.)	
P16PIP	Pipe & Duct Inspection Probe & Reel Set	01578 0	28mm (1.1 in.)	22m (72 ft.)	0.4 in. (10mm) to infinity

---

## **WARRANTY INFORMATION**

General Tools & Instruments' (General's) DCS1800ART High-Performance Wireless Recording Video Borescope System with Articulating Probe is warranted to the original purchaser to be free from defects in material and workmanship for a period of one year. Subject to certain restrictions, General will repair or replace this instrument if, after examination, the company determines it to be defective in material or workmanship.

This warranty does not apply to damages that General determines to be from an attempted repair by non-authorized personnel or misuse, alterations, normal wear and tear, or accidental damage. The defective unit must be returned to General Tools & Instruments or to a General-authorized service center, freight prepaid and insured.

Acceptance of the exclusive repair and replacement remedies described herein is a condition of the contract for purchase of this product. In no event shall General be liable for any incidental, special, consequential or punitive damages, or for any cost, attorneys' fees, expenses, or losses alleged to be a consequence of damage due to failure of, or defect in any product including, but not limited to, any claims for loss of profits.

---

## **RETURN FOR REPAIR POLICY**

Every effort has been made to provide you with a reliable product of superior quality. However, in the event your instrument requires repair, please contact our Customer Service to obtain an RGA (Return Goods Authorization) number before forwarding the unit via prepaid freight to the attention of our Service Center at this address:

General Tools & Instruments  
80 White Street  
New York, NY 10013  
212-431-6100

Remember to include a copy of your proof of purchase, your return address, and your phone number and/or e-mail address.



# **Specialty Tools & Instruments**

---

## **GENERAL TOOLS & INSTRUMENTS**

80 White Street

New York, NY 10013-3567

**PHONE (212) 431-6100 FAX (212) 431-6499**

**TOLL FREE (800) 697-8665**

e-mail: [sales@generaltools.com](mailto:sales@generaltools.com)

[www.generaltools.com](http://www.generaltools.com)

DCS1800ART User's Manual

Specifications subject to change without notice

©2012 GENERAL TOOLS & INSTRUMENTS

NOTICE - WE ARE NOT RESPONSIBLE FOR TYPOGRAPHICAL ERRORS.

MAN#DCS1800ART 6/28/12