

CUP ANEMOMETER BAROMETER HUMIDITY/TEMP.

Model : CAF4224



Your purchase of this METER marks a step forward for you into the field of precision measurement.

Although this METER is a complex and delicate instrument, its durable structure will allow many years of use if proper operating techniques are developed. Please read the following instructions carefully and always keep this manual within easy reach.



OPERATION MANUAL

TABLE OF CONTENTS

1. FEATURES.....	1
2. SPECIFICATIONS.....	2
2-1 General Specifications.....	2
2-2 Electrical Specifications.....	3
3. FRONT PANEL DESCRIPTION.....	5
3-1 Cup Vane.....	5
3-2 Humidity/Temp. Sensor.....	5
3-3 Power (▲) Button.....	5
3-4 Hold (◀) Button, Unit Button.....	5
3-5 REC (▼) Button, Mode Button.....	5
3-6 LCD Display.....	5
3-7 Battery Compartment/Cover.....	5
4. INSTALL THE VANE CUP.....	6
5. MEASURING PROCEDURE.....	7
5-1 Mode (Function) selection.....	7
5-2 Unit selection.....	8
5-3 Anemometer measurement.....	9
5-4 Barometer measurement.....	10
5-5 Humidity measurement.....	10
5-6 Dew point measurement.....	10
5-7 Data Hold.....	11
5-8 Data Record (Max., Min. reading).....	11
5-9 Auto power off management.....	12
6. BATTERY REPLACEMENT.....	12

1. FEATURES

- * Cup Anemometer, Barometer, Humidity, Temperature meter, 4 in one, professional.
- * Anemometer unit : m/S, Km/h, FPM, mph, Knot.
- * Barometer unit : hPa, mmHg, inHg.
- * Humidity with Dew point measurement
- * Temperature measurement with °C, °F unit.
- * Cup vane anemometer, available for wind speed measurement, high reliability.
- * Fast response time for humidity measurement.
- * Atmosphere measurement with high accuracy.
- * Two display can select the six mode (function) : Humidity/Temp., Humidity/Dew point, Anemometer/Temp., Barometer/Temp. Barometer/Humidity, Barometer/Anemometer,
- * Bright LCD display.
- * Microprocessor circuit ensures high accuracy and provides special functions and features.
- * Records Maximum and Minimum readings with recall.
- * Auto power off saves battery life.
- * Operates from DC 1.5V (UM4/AAA) x 4 PCs batteries.
- * Low-friction ball vane wheels is accurate in both high and low velocities.
- * Durable, long-lasting components, enclosed in strong, compact ABS-plastic housing.

2. SPECIFICATIONS

2-1 General Specifications

Display	LCD size : 28 mm x 19 mm.	
Anemometer Unit	m/S (meters per second) Km/h (kilometers per hour) FPM (feet per minute) mph (miles per hour) Knot (nautical miles per hour)	
Temp. unit	°C, °F	
Barometer unit	hPa, mmHg, inHg.	
Humidity unit	%RH	
Dew point	°C, °F	
Circuit	Custom one-chip of microprocessor LSI circuit.	
Sensor Structure	Anemometer	Cup van probe with low friction ball bearing design.
	Barometer	Semiconductor
	Humidity	Capacitance humidity sensor, semiconductor
	Temperature	Semiconductor
Data Hold	Freeze the display reading.	
Memory Recall	Maximum & Minimum value.	
Sampling Time	Approx. 1 second.	
Power off	Auto shut off saves battery life or manual off (REC function).	
Operating Temperature	0 to 50 °C.	
Operating Humidity	Less than 80% R.H.	

Power Supply	DC 1.5 V battery (UM4/AAA) x 4 PCs,
Power Current	Approx. DC 5.2 mA
Weight	182 g/ 0.4 LB. @ Battery is included.
Dimension	<i>Main instrument :</i> 190 x 40 x 32 mm (7.5" x 1.6" x 1.3")
	<i>Cup vane (3 cups with arm) :</i> 135 mm dia.
Accessories	Instruction manual..... 1 PC
Included	Hard carrying case..... 1 PC

2-2 Electrical Specifications (23± 5 °C)

Anemometer (Air velocity)

<i>Measurement</i>	<i>Range</i>	<i>Resolution</i>	<i>Accuracy</i>
m/S	0.9 - 35.0 m/S	0.1 m/S	± (2%+0.2 m/S)
Km/h	2.5 - 126.0 Km/h	0.1 Km/h	± (2%+0.8 Km/h)
FPM	144 - 6895 Ft/min	1 Ft/min	± (2%+40 Ft/min)
mph	1.6 - 78.2 Mile/h	0.1 Mile/h	± (2%+0.4 Mile/h)
Knot	1.4 - 68.0 Knots	0.1 Knots	± (2%+0.4 Knots)
<i>Note :</i>			
<i>m/S (meters per second)</i>		<i>mph (miles per hour)</i>	
<i>Km/h (kilometers per hour)</i>		<i>Knot (nautical miles per hour)</i>	
<i>FPM (feet per minute)</i>			

Temperature

Measuring Range	0 °C to 50 °C / 32 °F to 122 °F
Resolution	0.1 / 0.1 °F
Accuracy	± 0.8 / 1.5 °F

Humidity / Dew point

a. Humidity

Range	10 % to 95 % R.H.
Resolution	0.1 % R.H.
Accuracy	$\geq 70\%$ RH $\pm (3\% \text{ reading} + 1\% \text{ RH})$. $< 70\%$ RH - 3% RH. $\pm 3\%$ RH.

b. Dew point

°C	Range	-25.3 °C to 48.9 °C
	Resolution	0.01 °C
°F	Range	-13.5 °F to 120.1 °F.
	Resolution	0.01 °F
<i>Remark :</i> <i>* Dew Point display value is calculated from the Humidity/Temp. measurement automatically.</i> <i>* The Dew Point accuracy is sum accuracy value of Humidity & Temperature measurement..</i>		

Barometer

<i>Measurement</i>	<i>Range</i>	<i>Resolution</i>	<i>Accuracy @ reading</i>
hPa	10.0 to 999.9	0.1	± 1.5 hPa
	1000 to 1100	1	± 2 hPa
mmHg	7.5 to 825.0	0.1	± 1.2 mmHg
inHg.	0.29 to 32.48	0.01	± 0.05 inHg

** Above specification tests under the environment RF Field Strength less than 3 V/M & frequency less than 30 MHz only.*

3. FRONT PANEL DESCRIPTION

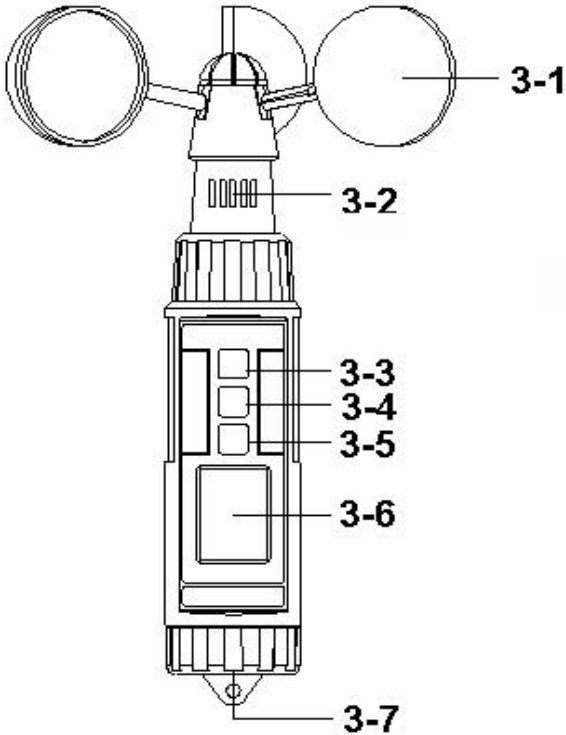
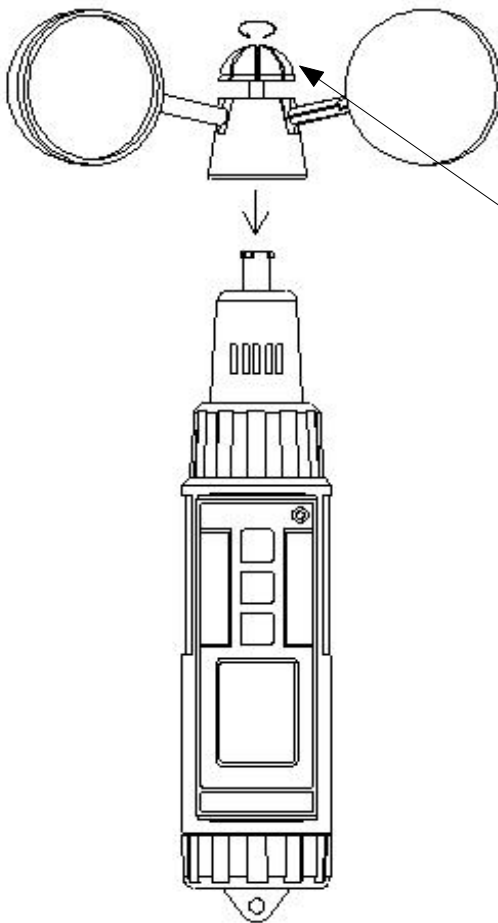

Fig. 1

- 3-1 Cup Vane
- 3-2 Humidity/Temp. Sensor
- 3-3 Power (▲) Button
- 3-4 Hold (←) Button, Unit Button
- 3-5 REC (▼) Button, Mode Button
- 3-6 LCD Display
- 3-7 Battery Compartment/Cover

4. INSTALL THE VANE CUP



Rotate the top screw in counter clockwise direction until the screw is secured.

5. MEASURING PROCEDURE

5-1 Mode (Function) selection

1) Turn on the meter by pressing the " Power Button " (3-3, Fig. 1) momentarily.

** Pressing the " Power Button " (3-3, Fig. 1) momentarily again will turn off the meter.*

2) The meter can select 6 kind mode (function) as :

- a. Humidity/Temp.**
- b. Humidity/Dew point**
- c. Anemometer/Temp.**
- d. Barometer/Temp.**
- e. Barometer/Humidity**
- f. Barometer/Anemometer**

Pressing the " Mode Button " (3-5, Fig. 1) continuously at least 2 seconds, both upper and the lower display value will be flashed, use the " ▲ Button " (3-3, Fig. 1) or " ▼ Button " (3-5, Fig. 1) to select the one kind mode (function) of above a, b, c, d, e, f, then press " ◀ Button " (3-4, Fig. 1) to entry the selecting mode.

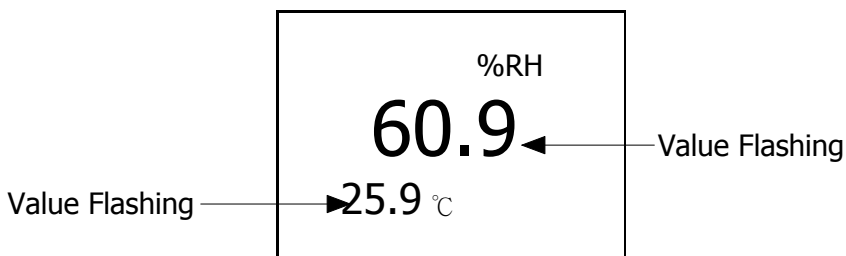

** After the mode (function) is selected, it will be memorized into the memory circuit .
If power off and on again will present the existing selection mode (function) .*

5-2 Unit selection

1) Turn on the meter by pressing the " Power Button " (3-3, Fig. 1) momentarily.

** Pressing the " Power Button " (3-3, Fig. 1) momentarily again will turn off the meter.*

2) Pressing the " Unit Button " (3-4, Fig. 1) continuously at least 2 seconds, both upper and the lower unit will be flashed, use the " ▲ Button " (3-3, Fig. 1) to select the upper display's unit, use the " ▼ Button " (3-5, Fig. 1) to select the lower display's unit, then press " ◀ Button " (3-4, Fig. 1) to entry the selecting unit.

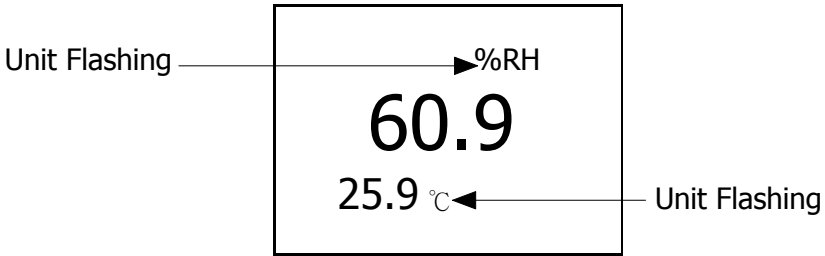

The measuring unit for different mode (function) are :

Anemometer unit	m/S, Km/h, FPM, mph, Knot
Temp. unit	°C, °F
Barometer unit	hPa, mmHg, inHg.
Humidity unit	%RH
Dew point	°C, °F

** After the unit is selected, it will be memorized into the memory circuit. If power off and on again will present the existing selection unit.*

5-3 Anemometer measurement

- 1) Turn on the meter by pressing the " Power Button " (3-3, Fig. 1) momentarily.
- 2) For the above 5-1 mode (function) selection, please set to :

c. Anemometer/Temp.

(Upper display show air velocity value, lower display show Temp. value)

f. Barometer/Anemometer

(Upper display show atmosphere value , lower display show air velocity value)

5-4 Barometer measurement

- 1) Turn on the meter by pressing the " Power Button "
(3-3, Fig. 1) momentarily.
- 2) For the above 5-1 mode (function) selection, please set to :

d. Barometer/Temp.

(Upper display show atmosphere value , lower display show Temp. value)

e. Barometer/Humidity

(Upper display show atmosphere value , lower display show humidity value)

f. Barometer/Anemometer

(Upper display show atmosphere value , lower display show air velocity value)

5-5 Humidity measurement

- 1) Turn on the meter by pressing the " Power Button "
(3-3, Fig. 1) momentarily.
- 2) For the above 5-1 mode (function) selection, please set to :

a. Humidity/Temp.

(Upper display show humidity value , lower display show Temp. value)

e. Barometer/Humidity

(Upper display show atmosphere value , lower display show humidity value)

5-6 Dew point measurement

- 1) Turn on the meter by pressing the " Power Button "
(3-3, Fig. 1) momentarily.
- 2) For the above 5-1 mode (function) selection, please set to :

b. Humidity/Dew point

(Upper display show humidity value , lower display show dew point value)

5-7 Data Hold

- * During the measurement, press the " Hold Button " (3-4, Fig. 1) momentarily to hold the measured value. The LCD will show a " HOLD " symbol.
- * Press the " Hold Button " once again to release the data hold function.

5-8 Data Record (Max., Min. reading)

- 1) The data record function records the maximum and minimum readings. Press the " REC Button " (3-5, Fig. 1) momentarily to start the Data Record function, shows " REC " on the display.
- 2) With the " REC " symbol on the display.
 - a) Press the " REC Button " (3-5, Fig. 1) momentarily, the " REC MAX " symbol along with the maximum value will appear on the display.
 - b) Press the " REC Button " (3-5, Fig. 1) momentarily again, the " REC MIN " symbol along with the minimum value will appear on the display.

** When display shows " REC MAX " or " REC MIN ", press the " Hold Button " (3-4, Fig. 1) momentarily will delete the max. (min.) value, the display will show the " REC. " only and execute the memory function continuously.*

- c) To exit the memory record function, press the " REC " button for 2 seconds at least. The display will revert to the current reading, not show " REC "

5-9 Auto power off management

- 1) The instrument has built-in "Auto Power Shut-off" function in order to prolong battery life. The meter will switch off automatically if none of the buttons are pressed within 10 min.
- 2) To de-activate this feature, Select the memory record function during measurement, by pressing the " REC Button " (3-5, Fig. 1).

6. BATTERY REPLACEMENT

- * Replace the batteries when the left corner of the LCD displays the low battery icon "  ", using 4 fresh 1.5 V (UM4, AAA) batteries.
- * To change the batteries, open (rotate clockwise direction) the " Battery Cover " (3-7, Fig. 1).
- * Make sure the " Battery cover " (3-7, Fig 1) is secured after changing the batteries.